

ELKA BARRIER SYSTEMS

Series KOLOSS



ELKA barriers of the series KOLOSS are designed for the protection of industrial entrances up to 12,000mm width and can be operated with folding skirts and folding top and bottom skirts. Perfect running performance, achieved by electronic speed control, protect motor and gear. An efficient drive concept and robust components ensure intensive operation with 100% duty cycle.

ELKA offers a selection of 3 barrier types of this series with different effective boom lengths and running times as well as suitable accessories for different purposes.



Shortening of the barrier boom to the required length is free of charge



Optionally available in all RAL custom colours

Operation of legal and standard-compliant barriers

ELKA barriers of the KOLOSS series fulfill the requirements of the European Union. There is a declaration of conformity according to the machine directive and a declaration of performance according to the Construction Products Regulation.

ELKA creates the prerequisite that operators and commissioning engineers are always on the safe side when it comes to questions of liability.

Technology in detail

- **Housing hood**

simple removal,
without tools

- **Robust mechanics**

for intensive operation with
high duty cycle, with vandalism
protection

- **Cable bushing**

comfortable - plenty of room

- **Efficient drive concept**

powerful 230V gear

- **Controller**

electronic speed control

- **Top-hat rail**

space for additional installations

- **Spring assembly**

Tension springs for 100,000 cycles

- **Barrier boom made of aluminium**

middle boom connector,
left / right usable, pre-assembled

- **Power reversal**

power reversal upon encountering
an obstacle

- **Emergency release**

fast and simple

- **Comfortable service**

power outlet for convenient working
on-site

- **Terminal row**

professional connection of
accessories

- **Loop detectors**

3 integrated loop detectors

- **Barrier housing**

made of aluminium, powder-coated,
IP 44

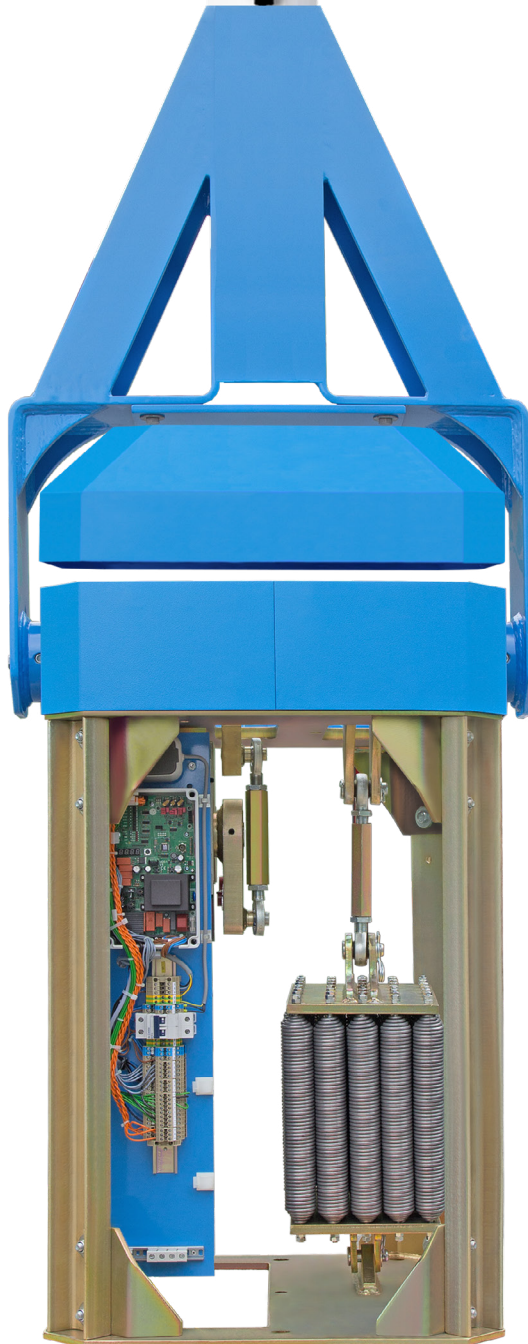

Folding skirts and folding top and bottom skirts made of aluminium

ELKA barriers of the series KOLOSS can be operated with folding skirts and folding top and bottom skirts:

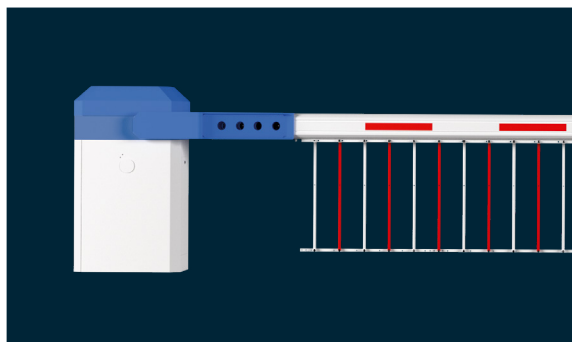

Folding skirt HG75

- ✓ Height 750mm
- ✓ Colour red / white
- ✓ Incl. spacer and guide plate for swinging support
- ✓ Max. boom length 10,000mm
- ✓ Pre-assembled for on-site installation

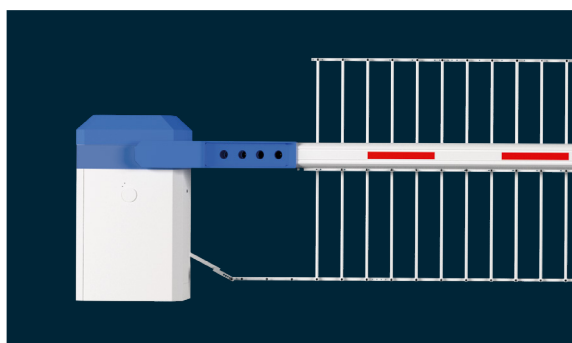

Folding top and bottom skirt SG150

- ✓ Height 1,500mm
- ✓ Colour white
- ✓ Incl. guide lever and spacer
- ✓ Max. boom length 6,000mm
- ✓ Pre-assembled for on-site installation

Laser scanner

For the safe detection of vehicles and persons during barrier operation where personal traffic cannot be excluded. The TÜV-certified protection device provides a reliable usage in case no induction loop can be used due to structural conditions. Pedestrian detection can be deactivated (during opening). Housings, pillars and posts optionally available in all RAL custom colours (extra charge).



Laser scanner for free-standing installation

Laser scanner in a free-standing pillar for a monitoring field on the left and right side of the barrier boom with reference posts, available in two sizes. A reference post with reflector foil is required if no wall with reflector foil can be used as a reference object.



Laser scanner for mounting on the barrier housing

Laser scanner in a housing for a monitoring field on the left and right side of the barrier boom. For on-site installation on the barrier housing. A fixed post with reflector foil is required if no wall with reflector foil can be used as a reference object.

Configuration example: with folding skirt or folding top and bottom skirt

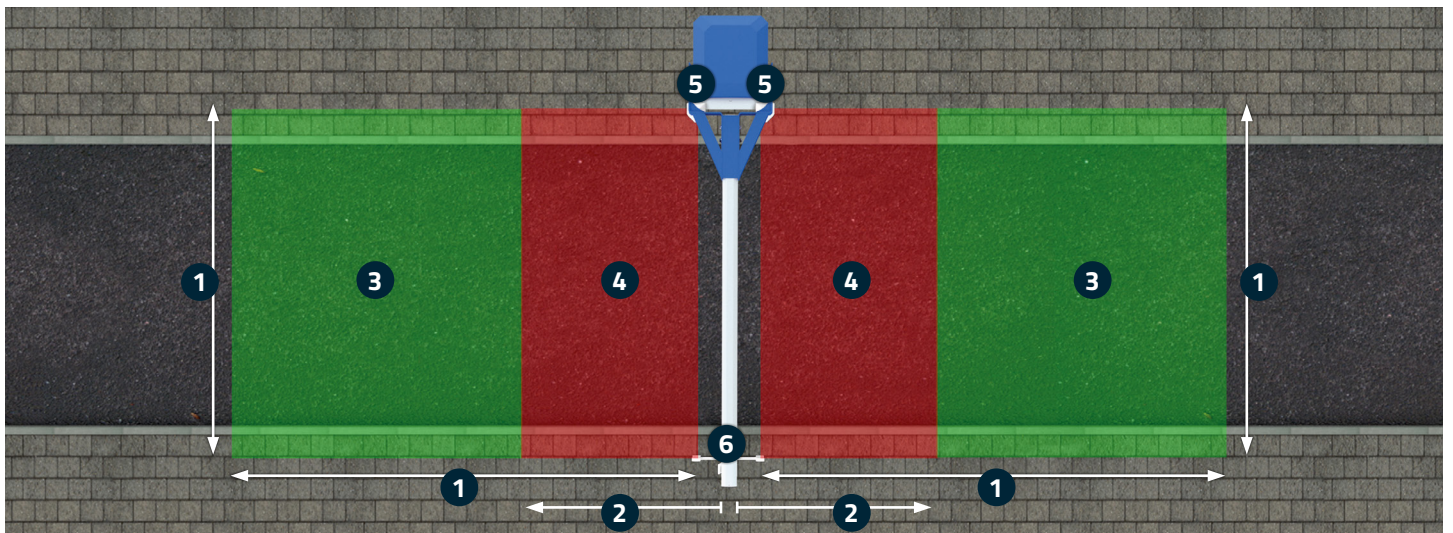

(1) Field dimension max. 9,900mm

(2) Security area, distance max. 200mm from the barrier boom

(3) Opening field

(4) Security field

(5) Laser scanner in housing, mounted on barrier housing

(6) Reference post with reflector foil

ELKA ECON APP



App for programming and controlling of ELKA barriers

Programming, operation and control of ELKA barriers with controller MO 24 and MO 64 „Plus“ - comfortable via mobile phone, tablet or PC. Only usable in combination with the ELKA ECON BOX.

Quick set-up

Simple project management, barrier configurations can be set and saved, backup of all settings

Professional maintenance

Analysing of the induction loops, error memory, service- and diagnostic report, diagnosis of all inputs and outputs of the controller

Comfortable

Notification and control of events in case of a status change, user management, 365-day-timer, differential counter

Access control devices



Radio remote control

1-, 2- or 4-channel,
434MHz or 868MHz,
codable, very good range



Desktop panels

Single, double, triple or quadruple
keyboard, with illuminated keys,
OPEN / CLOSE / STOP / ON-OFF



Switches

Flush or surface mounting, key switches
including key, code switches with foil keypad
or stainless steel keypad

[You can find further access controls here.](#)

Technical data

Type	KOLOSS 60	KOLOSS 90	KOLOSS 120
Housing dimensions (w/d/h) (mm)	656 x 720 x 1,250		
Boom length (mm)	6,000	9,000	12,000
Effective boom length approx. (mm)	6,180	9,180	12,180
Running time approx. (s)	6.0	9.0	12.0
Max. cycles per hour	150	100	75
Temperature range	-20°C up to +50°C		
Degree of protection	IP44		
Supply voltage	230V, 50Hz		
Current consumption	max. 10A (230VAC)		
Weight without boom approx. (kg)	425	450	475
Boom weight approx. (kg)	27	58	71.5

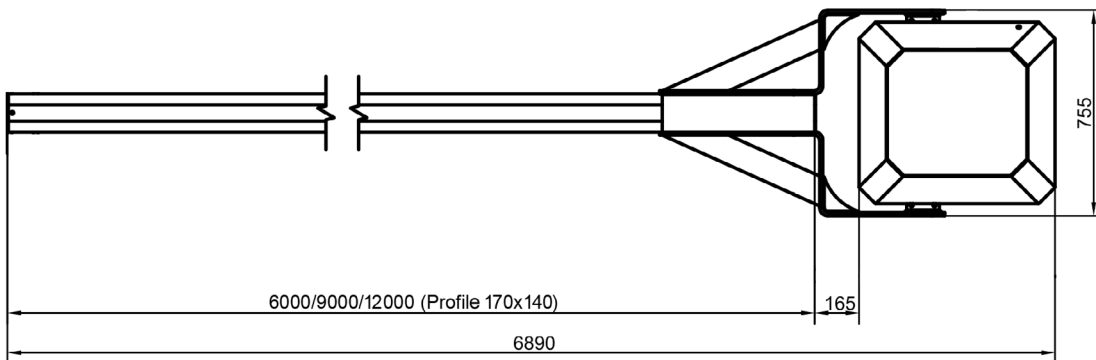
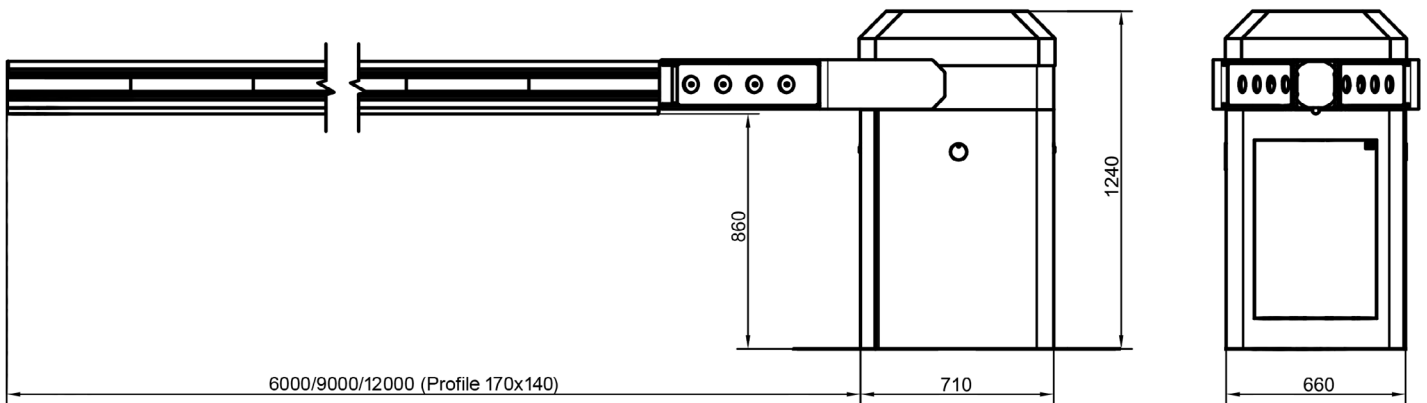

Equipment

Standard equipment	KOLOSS 60	KOLOSS 90	KOLOSS 120
Standard colours	Housing white / RAL 9010, housing hood blue / RAL 5012		
Boom connector	Middle boom connector		
Boom dimensions h/w (mm)	170 x 140		
Controller	MO 64 „Plus“ with 4x7-segment-display		
Power reversal	connectable		
Terminal row	prewired		
1-channel loop detector	3 integrated		
Multifunctional relay	6 integrated (e.g. for traffic lights, boom lighting LED, etc.)		
Electronic speed control	yes		
Dead man's mode	yes		
Antenna connection	yes		

Special equipment	KOLOSS 60	KOLOSS 90	KOLOSS 120
Articulation kit	no		
Round barrier boom	no		
Fixed and swinging support	optional	mandatory	
Folding skirts and folding top and bottom skirts	HG 75, SG 150	HG 75, SG 150 (up to 6,000mm)	HG 75 (up to 10,000mm), SG 150 (up to 6,000mm)
Boom lighting	mounted on the boom		
Custom colours	optionally available in all RAL custom colours (extra charge)		
Photoelectric barrier	optional		
Laser scanner	optional, free-standing installation or mounting on the barrier housing (two laser scanners are required when using folding skirts or folding top and bottom skirts)		
24V loading module	no		
Automatic OPENING	no		
Radio remote control receiver	optional (socket available)		
Weekly timer / yearly timer	optional		
TCP-IP-module	optional (socket available)		
Multifunctional relay	no additional module (6 already integrated)		
Access control	Key switch, code switch, etc.		

ELKA TORANTRIEBE

Partner with competence



ELKA is a German manufacturer of gate openers and barrier systems of high quality with an experience of more than 40 years. We place a great value on high quality components, easy installation and customerfriendly service. Our products are developed and assembled in Germany and are subject to strict quality controls.

„Partner with competence“ - the management as well as the employees feel committed to this philosophy. We supply products to over 80 countries worldwide and support our customers in three languages. Technically trained specialists and engineers respond to individual customer requirements. Fast order processing, short delivery times and adherence to deadlines are a matter of course for us.

You can find more information on our website: www.elka.eu

✓ **Competent customer service**

✓ **Quality „Made in Germany“**

✓ **Prompt handling and reliability**

Inhouse-Seminars

Gate openers- and barrier seminar with expert certificate. According to legal regulations, power-operated gate and barrier systems must be checked at least once a year. Only experts with a valid certificate are authorized to carry out the inspection and documentation. ELKA supports its partners in this and offers further training in its own premises in Tönning, Germany.

The ELKA team is looking forward to your questions and registrations: akademie@elka.eu



ELKA-Torantriebe GmbH u. Co. Betriebs KG
Dithmarscher Str. 9, 25832 Tönning / Germany

✉ info@elka.eu

🌐 www.elka.eu

☎ **+49 (0) 4861-9690-0**

📠 **+49 (0) 4861-9690-90**